

# INTERNATIONAL FORTRESS PAWNSAFE

*The next generation Pawnsafe*

- **UL Listed TL-30**  
Six-sided composite construction incorporates a steel and ceramic matrix on all six sides of the safe.
- **Best in Class**  
Unified construction achieves the highest degree of burglary protection in its class.
- **Capacity**  
Large capacity steel drawers hold up to 25 lbs. per drawer
- **Robbery Protection**  
Advanced time-delay security prohibits interior drawers opening all at once.
- **Fire Protection**  
Factory tested 2-hour fire rating



RETAIL



FINANCIAL



AMUSEMENT



HOSPITALITY



GAMING



RESTAURANTS



JEWELRY



# INTERNATIONAL FORTRESS PAWNSAFE

Offering premium security in a six-sided composite TL-30 safe at an affordable price



- **Boltwork**

The massive 1.5" chrome plated bolts are secured with dual Underwriters Laboratories Group 2M combination locks.

- **Drawer Control**

Control drawers by time, date, and person with audit capabilities

## Specifications

Dimensions (in.)	Weight
57½ H x 34½ W x 36½ D	4,200 lbs.

## Door Swing Dimensions

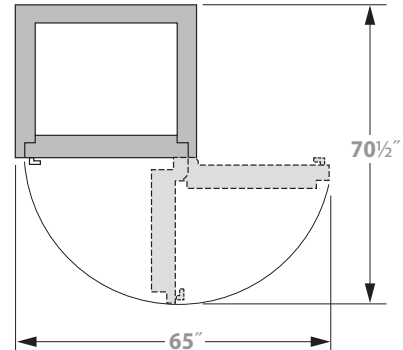

Left hand door swings also available by special order  
 Add 2" to exterior depth for hinge projection  
 Add 2" to exterior depth for removable handle projection  
 Add 4" to height for removable metal transport base

- **Rapid Use Penalty**

Triggers system to shut down

- **Time Delay**

For timed access to drawers

- **Individual Drawer Programming**

Customize inventory organization

- **Control Access**

Program up to 20 users

- **Audit Capability**

Comprehensive reports

- **Time Lock**

Access only during business hours

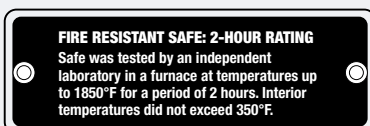
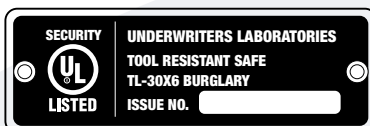

All specifications are approximate and subject to change without notice.

Distributed By:



510 Washington Blvd.  
 Montebello, CA 90640  
 (323) 724-5880 Telephone  
 (800) 334-6060 Toll Free  
 (323) 727-0236 Fax  
[www.socalsafe.com](http://www.socalsafe.com)

©2018 Socal Safe Company. All Rights Reserved 2018-11-27\_V01

Learn More at:  
[www.socalsafe.com](http://www.socalsafe.com)  
 or call your  
 Socal Safe  
 Security Expert  
 Toll-Free  
**800-334-6060**